

INTERAK COMPUTER SYSTEM

Analogue to Digital - 4 Port Module

AP 2008



This module provides 4 Analogue Ports for the Interak. It is designed to be used with the I/O Port card.

The IC used is an ADC0809 - this IC can provide 8 analogue ports but by using 4, only 2 address lines are required, leaving one free to select the End of Conversion signal.

OPERATION

In use the required port is written to (any data) to start the conversion. After the end of conversion the resultant voltage (0 to 5V) can be read at the port as 8-bit data 0 to 255.

The conversion time is 142µs using the 500kHz clock and during this time the EOC signal is low. When using BASIC there is no need to check for end of conversion.

i.e. In BASIC using Port 10H (16 decimal) - Analogue voltage connected to Vin 0

```
10 P=16          (set Port as 16)
20 OUT P,0       (start conversion)
30 V=INP(P)      (get voltage in variable V)
```

and in Z80 assembler

```
Port EQU 010H
EOC EQU 014H      ;any port 14H to 17H

        OUT (Port),A      ;start conversion at Port (any data in A)
        NOP                ;wait for EOC signal to go low
LCON: IN  A,(EOC)         ;has conversion ended?
        AND 01H           ;check bit 0 - is EOC high?
        JP  Z,LCON        ;no - keep checking
        IN  A,(Port)      ;get voltage as data (0 to 255)
```

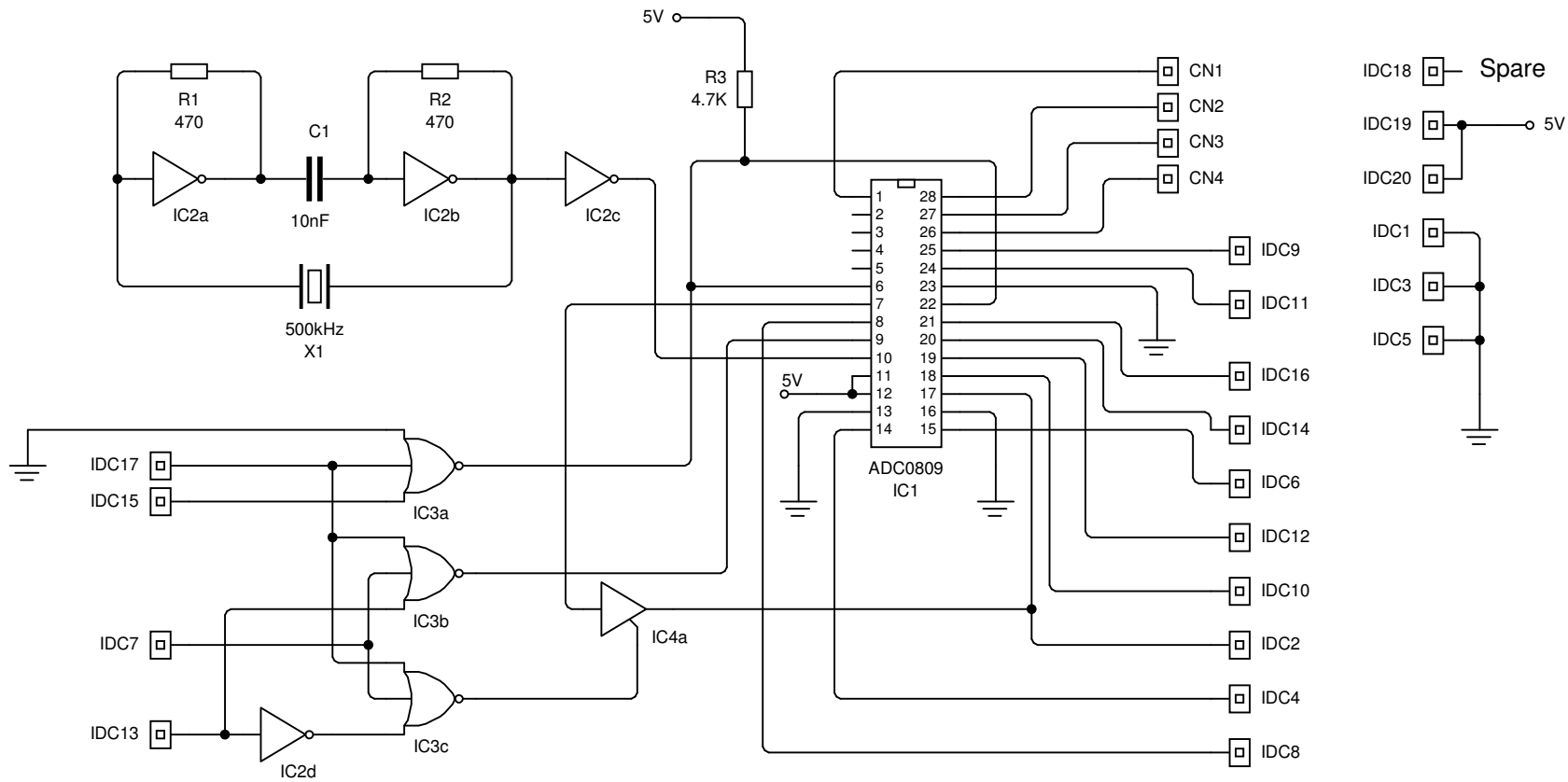

INTERAK COMPUTER SYSTEM Analogue to Digital - 4 Port Module

- IC1 ADC0809 Analogue to Digital Converter
- IC2 74S04 Hex Inverter
- IC3 74LS27 Triple 3-Input NOR gate
- IC4 74LS126 Quad 3-State Buffer (active high)
- IDC 1 to 20 20-way IDC plug (male)
- CN 1 to 4 8-way input connector (4x Vin + Gnd)